

PIPE SYSTEMS



Snow-Making Systems

VRS[®]-T pressure pipes

ductile iron solutions
www.trm.at



Table of contents

+ Restrained locking systems VRS®-T joint	page	2
+ VRS®-T Joint DN 80 to DN 250	page	4
+ VRS®-T Joint DN 300 to DN 500	page	5
+ VRS®-T Joint with clamping ring DN 80 to DN 500	page	6
+ VRS®-T Joint DN 600	page	7
+ Bolted-gland socket joint (STB) DN 600	page	8
+ Flange Joint DN 80 to DN 600	page	9
+ Dimensions DN 80 to DN 600	page	10
+ VRS®-T Pressure Pipes DN 80 to DN 600 standard overall length 5.0 m	page	12
+ Snow-Specific Information Tiroler Rohre GmbH – a strong partner	page	16
+ Checklist For constructors and planners	page	17



Restrained locking systems

VRS®-T joint

Different forces act on the pipe and the joint. The decisive factors here are the earth pressure, static and dynamic loads from the soil above, traffic and, of course, the internal pressure. Tensile forces at the joint and friction forces play a particularly important role in trenchless installation, and restrained locking systems absorb all these forces.

Joint structure

A restrained socket consists of two separate chambers: a retaining chamber and a sealing chamber. The forces are transmitted from one pipe / fitting to the other via the welded bead and the locking elements into the socket. The design of the joint is the same for pipes and fittings.

The joint acts as a longitudinally displaceable connection and can withstand high loads. It remains sealed even under maximum decentering or joint-bending conditions, as proven by the type tests according to EN 545.

▲ Thrust blocks to absorb the internal forces are not necessary – and mobility in the joint is maintained.

▲ Tiroler Rohre GmbH offers pipe system tests (type tests) according to ÖNORM EN 545 and ÖNORM EN 598 for all DN and pressure ratings.



VRS®-T joint DN 80 to DN 500



VRS®-T joint DN 600



VRS®-T joint with clamping ring DN 80 to DN 500

Allowable pressures

acc. to EN 545 + EN 805

PFA-allowable operating pressure

(highest hydrostatic pressure that a pipe component can withstand in continuous operation)

PMA highest allowable operating pressure

(highest temporary pressure, including pressure surges, that a pipe component can withstand during operation)
= 1.2 x PFA

PEA-allowable test pressure

(highest hydrostatic pressure that a newly installed pipe component can withstand for a relatively short time to ensure the integrity and leak-tightness of the pipe)
= 1.2 x PFA + 5 bar

- ⚠ The allowable test pressure (PEA) differs from the system test pressure (STP), which relates to the calculation pressure of the pipe and serves to maintain its condition and leak-tightness.

Negative internal pressure

Ductile iron pipes and fittings can be used for negative pressures of up to -0.6 bar (continuous) or -0.9 bar (short-term).

Pressure classes (C classes)

According to EN 545, restrained locking systems are not classified into C classes, so the dimensions deviate from those of pipes according to EN 545 Table 17 (pipes with non-restrained locking systems).

Consistent system

Restrained locking systems made by different manufacturers cannot be combined because they use different force-transmission elements, have different welded-bead designs and are located at different distances from the pipe end.

- ⚠ For possible solutions, please contact our application engineering department.



VRS®-T EPDM gasket ring according to EN 681-1



VRS®-T lock set



VRS®-T lock set with high-pressure lock (HDR)

VRS®-T Joint

DN 80 to DN 250

VRS®-T joint with tension and shear protection according to ÖNORM B 2597. Separate retaining and sealing chamber, spigot with welded bead.

VRS®-T joint set DN 80 to DN 250:

- + VRS®-T EPDM gasket ring according to EN 681-1
- + VRS®-T lock set:
 - 1 lock, right (black)
 - 1 lock, left (red)
 - 1 catch
- + High-pressure lock (HDR – optional)

⚠ HDRs are used at the VRS®-T joints in nominal diameters DN 150 to DN 250 for the following pressure ratings:

- + DN 150 – PN 85
- + DN 200 – PN 85 + PN 100
- + DN 250 – PN 63 + PN 85 + PN 100



VRS®-T EPDM gasket ring according to EN 681-1



VRS®-T lock set

VRS®-T Joint

DN 300 to DN 500

VRS®-T joint with tension and shear protection according to ÖNORM B 2597. Separate retaining and sealing chamber, spigot with welded bead.

VRS®-T joint set DN 300 to DN 500:

- + VRS®-T EPDM gasket ring according to EN 681-1
- + VRS®-T lock set:
 - 2 locks, right (black)
 - 2 locks, left (red)
 - 2 catches



VRS®-T EPDM gasket ring according to EN 681-1



VRS®-T clamping ring for cut pipes

VRS®-T Joint with clamping ring

DN 80 to DN 500

VRS®-T joint with tension and shear protection according to ÖNORM B 2597. Separate retaining and sealing chamber, spigot without welded bead.

⚠ The installation instructions for clamping rings must be observed!

Clamping ring set DN 80 to DN 500:

- + VRS®-T EPDM gasket ring according to EN 681-1
- + VRS®-T split clamping ring:
 - 2 clamping ring halves
 - 2 hex bolts
 - 2 nuts
 - Tightening torque 60 Nm

Clamping rings can be used with cut VRS®-T pipes, which means that the customer does not need to use a welded bead. The clamping ring is a restrained locking system in which the claws of the clamping ring press into the outer wall of the pipe to secure the connection.

- ⚠** Avoid clamping rings in fittings!
- ⚠** Do not use clamping rings in above-ground pipes, in pipes subject to pulsation or in trenchless installations.



TYTON® EPDM gasket ring according to EN 681-1



VRS®-T locking set

VRS®-T Joint

DN 600

VRS®-T joint with tension and shear protection according to ÖNORM B 2597. Separate retaining and sealing chamber, spigot with welded bead.

VRS®-T joint set DN 600:

- + TYTON® EPDM gasket ring according to EN 681-1
- + VRS®-T locking set:
 - 9 locking segments
 - 1 tension strap or
 - 1 metal clip (only necessary for trenchless installation)

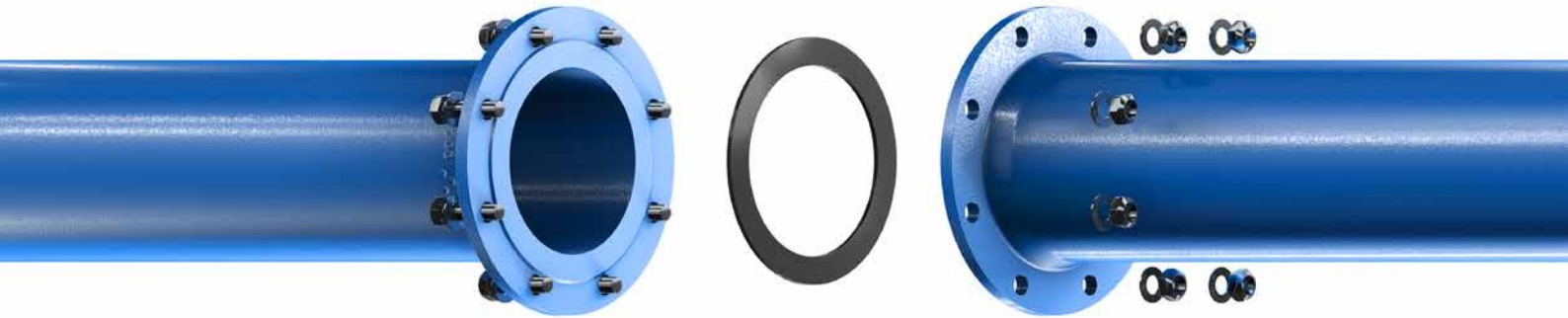

Bolt set



Gasket according to EN 1514-1

Flange Joint

DN 80 to DN 600

Flange joints are rigid but easily detachable joints. The allowable internal pressures are based not only on the wall thicknesses but also on the dimensions of the flanges and bolts as well as the flange gaskets used.

Joint structure

A flange joint consists of a pair of flanges, bolts, nuts and washers plus the gasket inserted between the two flanges, which is pressed together by bolts. The design of the joint is the same for pipes and fittings.

According to EN 1092-2 for PN 10 to PN 63 and according to EN 1092-1 for PN 100. Flanges that meet these standards can be connected to all flanges whose connecting dimensions comply with DIN 2501-1. Flanges can be attached by casting, screwing or welding.

⚠ Bolts, nuts, washers and gaskets are available from specialist dealers.



Bolted gland ring



Gland gasket



T-head bolts

Bolted-gland socket joint (STB)

DN 600

Bolted-gland socket joint according to DIN 28 602.

STB joint set DN 600 PN 16:

- + Gland ring (2 pcs.)
- + Gasket (2 pcs.)
- + 2x 16 T-head bolts M20 incl. nuts and washers
- + Gland socket

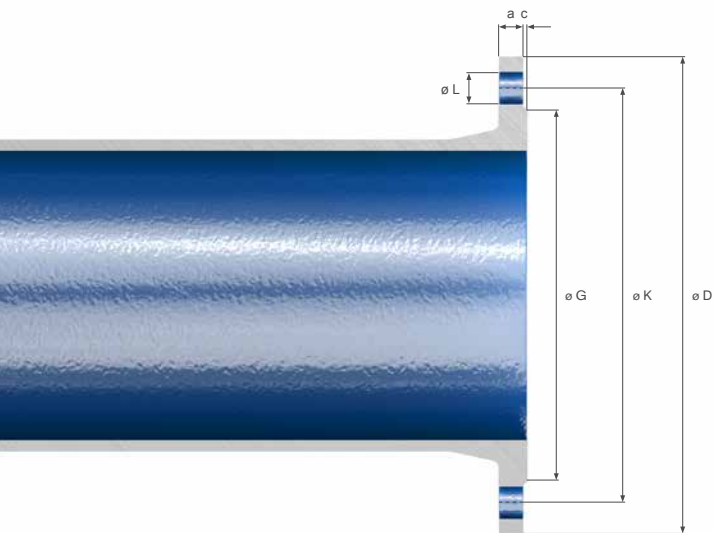

Dimensions

DN 80 to DN 600

Overview of technical data for integral flange (Type 21).

Bolts and gaskets are available from specialist dealers.

- + Hex bolts according to EN ISO 4016 or EN ISO 4018
- + Washers according to EN ISO 7091
- + Hex nuts according to EN ISO 4034
- + IBC gaskets according to EN 1514-1 with steel insert depending on the pressure rating

Technical data Dimensions ^{||}

DN	Flange					Sealing strip		Bolts		
	PN	$\varnothing D$	$\varnothing K$	$\varnothing L$ (hole)	a	$\varnothing G$	c	No.	Thread	SW
50	10	165	125	19	19	99	3	4	M16 x 70	24
	16	165	125	19	19	99	3	4	M16 x 70	24
	25	165	125	19	19	99	3	4	M16 x 70	24
	40	165	125	19	19	99	3	4	M16 x 70	24
	63	180	135	23	28	99	3	4	M20 x 90	30
	100	195	145	28	30	99	3	4	M24 x 100	36
80	10	200	160	19	19	132	3	8	M16 x 70	24
	16	200	160	19	19	132	3	8	M16 x 70	24
	25	200	160	19	19	132	3	8	M16 x 70	24
	40	200	160	19	19	132	3	8	M16 x 70	24
	63	215	170	23	31	132	3	8	M20 x 100	30
	100	230	180	28	32	132	3	8	M24 x 100	36
100	10	220	180	19	19	156	3	8	M16 x 70	24
	16	220	180	19	19	156	3	8	M16 x 70	24
	25	235	190	23	19	156	3	8	M20 x 70	30
	40	235	190	23	19	156	3	8	M20 x 70	30
	63	250	200	28	33	156	3	8	M24 x 110	36
	100	265	210	31	36	156	3	8	M27 x 120	41
125	10	250	210	19	19	184	3	8	M16 x 70	24
	16	250	210	19	19	184	3	8	M16 x 70	24
	25	270	220	28	23,5	184	3	8	M24 x 90	36
	40	270	220	28	23,5	184	3	8	M24 x 90	36
	63	295	240	31	37	184	3	8	M27 x 120	41
	100	315	250	34	40	184	3	8	M30 x 130	46

^I according to EN1092-2 for PN10-PN63

^{||} according to EN1092-1 for PN100

Technical data Dimensions II

DN	Flange						Sealing strip		Bolts		
	PN	ØD	ØK	ØL (hole)	a	ØG	c	No.	Thread	SW	
150	10	285	240	23	19	211	3	8	M20 x 70	30	
	16	285	240	23	19	211	3	8	M20 x 70	30	
	25	300	250	28	26	211	3	8	M24 x 90	36	
	40	300	250	28	26	211	3	8	M24 x 90	36	
	63	345	280	34	39	211	3	8	M30 x 130	46	
	100	355	290	34	44	211	3	12	M30 x 140	46	
200	10	340	295	23	20	266	3	8	M20 x 80	30	
	16	340	295	23	20	266	3	12	M20 x 80	30	
	25	360	310	28	22	274	3	12	M24 x 90	36	
	40	375	320	31	30	284	3	12	M27 x 110	41	
	63	415	345	37	46	284	3	12	M33 x 150	50	
	100	430	360	37	52	284	3	12	M33 x 160	50	
250	10	400	350	23	22	319	3	12	M20 x 80	30	
	16	400	355	28	22	319	3	12	M24 x 90	36	
	25	425	370	31	24,5	330	3	12	M27 x 90	41	
	40	450	385	34	34,5	345	3	12	M30 x 120	46	
	63	470	400	37	50	345	3	12	M33 x 150	50	
	100	505	430	40	60	345	3	12	M36 x 180	55	
300	10	455	400	23	24,5	370	4	12	M20 x 90	30	
	16	455	410	28	24,5	370	4	12	M24 x 90	36	
	25	485	430	31	27,5	389	4	16	M27 x 100	41	
	40	515	450	34	39,5	409	4	16	M30 x 130	46	
	63	530	460	37	57	409	4	16	M33 x 180	50	
	100	585	500	43	68	409	4	16	M39 x 200	60	
400	10	565	515	28	24,5	480	4	16	M24 x 90	36	
	16	580	525	31	28	480	4	16	M27 x 100	41	
	25	620	550	37	32	503	4	16	M33 x 120	50	
	40	660	585	40	48	535	4	16	M36 x 150	55	
	63	670	585	44	65	535	4	16	M39 x 200	60	
	100	715	620	50	78	535	4	16	M45 x 220	70	
500	10	670	620	28	26,5	582	4	20	M24 x 100	36	
	16	715	650	34	31,5	609	4	20	M30 x 120	46	
	25	730	660	37	36,5	609	4	20	M33 x 130	50	
	40	755	670	44	52	615	4	20	M39 x 180	60	
	63	800	705	48	68	615	4	20	M45 x 200	70	
	100	870	760	56	94	630	4	20	M52 x 260	80	
600	10	780	725	31	30	685	4	20	M27 x 100	41	
	16	840	770	37	36	725	4	20	M33 x 120	50	
	25	845	770	40	42	720	4	20	M36 x 140	55	
	40	890	795	50	58	735	4	20	M45 x 180	70	
	63	930	820	56	98	735	3	20	M52 x 260	80	

I according to EN1092-2 for PN10-PN63

II according to EN1092-1 for PN100



Black polyurethane coating for high-pressure applications

VRS[®]-T Pressure Pipes

DN 80 to DN 600
standard overall length 5.0 m

according to ÖNORM EN 545
and ÖNORM B 2597 with
VRS[®]-T restrained locking
systems.

Coating

Internal lining

+ Portland cement

▲ Special linings available on request

External coating

+ Zinc coating with PUR-Longlife coating

▲ Other coatings (e.g. zinc coating with PUR-TOP coating and zinc coating with ZMU-Austria coating) on request.

▲ For more detailed information, see the section on coatings.



Extremely resistant ZMU-Austria (cement-mortar coating)



WKG pipe, buried with PE-HD casing pipe



PUR-TOP coating



WKG pipe, open-air with spiral casing pipe

Labeling

Pressure pipes are labeled by cast markings and lettering.

Cast labels:

The pipes are labeled with the nominal diameter, the manufacturer's mark and the year inside the socket, i.e. at a suitable point where the function of the joint is not disturbed. These markings can be cast in embossed or grooved form. The parallel, curved grooves some 3 mm deep in the front of the socket further identify the material as "ductile iron". Short lengths of pipe (4 m or 4.5 m) are marked at the front of the socket.

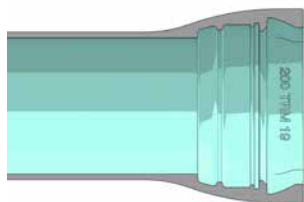

Nominal diameter, manufacturer's mark and year inside the socket.



Marking for short lengths of pipe (4 m or 4.5 m) at the front of the socket.

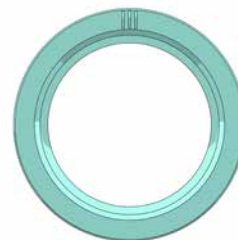

Marking for ductile iron at the front of the socket.

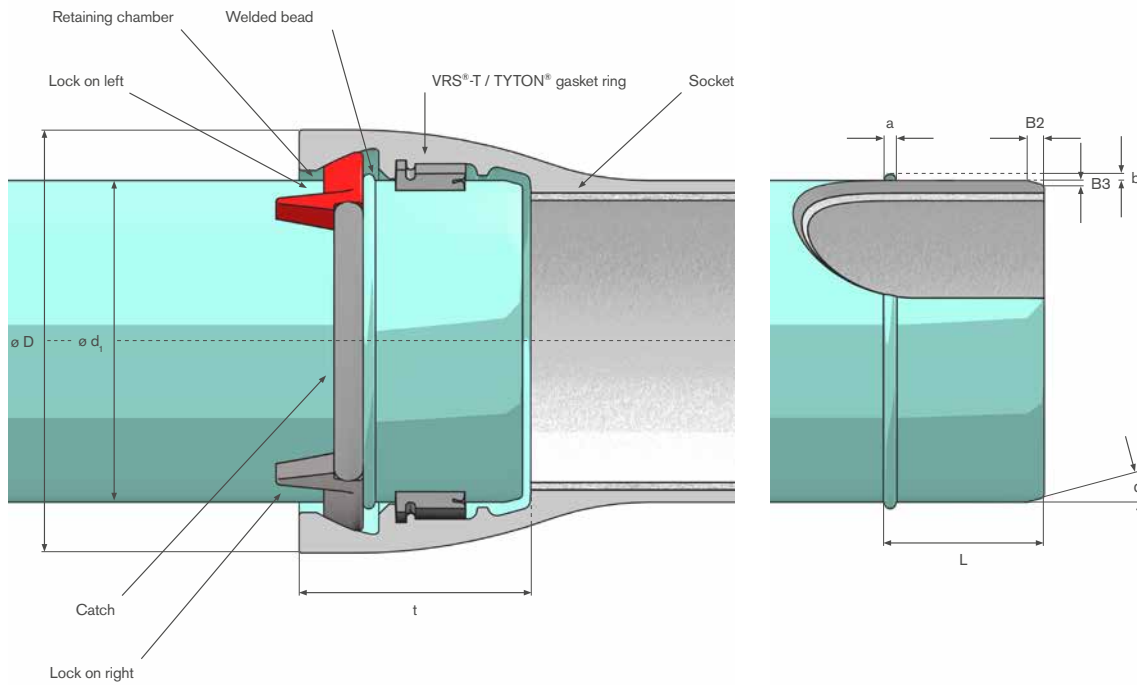

VRS[®]-T Pressure Pipes

DN 80 to DN 600

standard overall length 5.0 m

Overview of technical data for pipes with restrained locking systems.

VRS[®]-T joint DN 80 to DN 600

DN	Dimensions [mm] ^a								Bevel		
	Spigot diameter	Deviations	Socket diameter	Insertion depth	Welded bead			B2	B3		
	d1		D	t	L	a	b				
80	98	+1.0 -2.7	156	127	86 ±4	8 ±2	5 +0.5 -1	8-10	3-4	10	
100	118	+1.0 -2.8	177	135	91 ±4	8 ±2	5 +0.5 -1				
125	144	+1.0 -2.8	206	143	96 ±4	8 ±2	5 +0.5 -1				
150	170	+1.0 -2.9	232	150	101 ±4	8 ±2	5 +0.5 -1				
200	222	+1.0 -3.0	292	160	106 ±4	9 ±2	5.5 +0.5 -1				
250	274	+1.0 -3.1	352	165	106 ±4	9 ±2	5.5 +0.5 -1				
300	326	+1.0 -3.3	410	170	106 ±4	9 ±2	5.5 +0.5 -1				
400	429	+1.0 -3.5	521	190	115 ±5	10 ±2	6 +0.5 -1				
500	532	+1.0 -3.8	630	200	120 ±5	10 ±2	6 +0.5 -1	8-10	3-4	15	
600	635	+1.0 -4.0	732	175	116 +0 -2	9 ±1	6 +0.5 -1				

^a Tolerances are possible

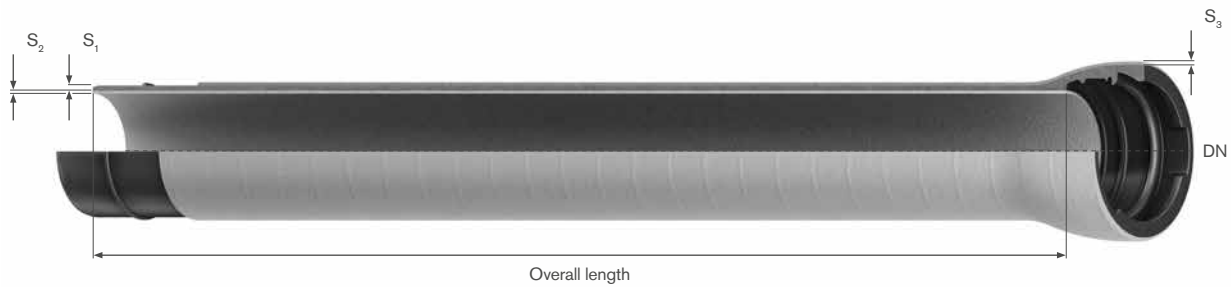

VRS[®]-T pipes DN 80 to DN 600

Description	PFA [bar] _a	Article no.	Dimensions [mm]			Weight per meter 5 m pipe [kg] _b	Weight per 5 m pipe [kg] _c	Number of locks or set of locks	alwbl. tensile forces [kN] acc. to TRM _d	max. bending [°]	min. radius [m]
			s ₁ Iron	s ₂ ZMA	s ₃ ZMU						
MDR DN 80	PN 100	106390001	4.7	4	5	16.3	81.6	2	115	5	57
MDR DN 100	PN 75	106390002	4.7	4	5	20.0	100.0	2	150	5	57
MDR DN 100	PN 100	106390003	5.2	4	5	21.4	107.0	2	225	5	57
MDR DN 125	PN 63	106390004	4.8	4	5	25.6	128.2	2	225	5	57
MDR DN 125	PN 100	106390005	6.1	4	5	29.1	145.5	2	225	5	57
MDR DN 150	PN 63	106390006	4.7	4	5	31.5	157.3	2	240	5	57
MDR DN 150, HDR	PN 85	106390071	6.4	4	5	35.9	179.7	3 _e	240	5	57
MDR DN 150	PN 100	106390007	7.7	4	5	40.4	201.8	2	240	5	57
MDR DN 200	PN 40	106390008	4.8	4	5	40.9	204.5	2	350	4	72
MDR DN 200, HDR	PN 63	106390104	4.8	4	5	40.9	204.5	3 _e	350	4	72
MDR DN 200, HDR	PN 85	106390072	6.9	4	5	50.5	252.7	3 _e	350	4	72
MDR DN 200, HDR	PN 100	106390073	9.0	4	5	60.1	300.5	3 _e	350	4	72
MDR DN 250	PN 40	106390011	5.2	4	5	53.8	268.9	2	375	4	72
MDR DN 250, HDR	PN 63	106390082	6.0	4	5	58.1	290.4	3 _e	375	4	72
MDR DN 250, HDR	PN 85	106390074	8.2	4	5	71.3	356.3	3 _e	375	4	72
MDR DN 250, HDR	PN 100	106390075	10.5	4	5	83.8	419.1	3 _e	375	4	72
MDR DN 300	PN 40	106390014	5.6	4	5	67.9	339.5	4	380	4	72
MDR DN 300	PN 63	106390076	9.6	4	5	95.1	475.7	4	380	4	72
MDR DN 300	PN 85	106390037	11.2	4	5	106.3	531.7	4	380	4	72
MDR DN 300	PN 100	106390269	14.4	4	5	127.4	637.0	4	380	4	72
MDR DN 400	PN 30	106390017	6.4	5	5	104.0	519.9	4	650	3	95
MDR DN 400	PN 35	106390077	8.2	5	5	120.4	601.8	4	650	3	95
MDR DN 400	PN 40	106390078	9.1	5	5	128.5	642.5	4	650	3	95
MDR DN 400	PN 45	106390029	10.0	5	5	136.6	682.9	4	650	3	95
MDR DN 400	PN 50	106390050	12.7	5	5	161.3	806.6	4	650	3	95
MDR DN 400	PN 63	106390080	12.7	5	5	161.3	806.6	4	650	3	95
MDR DN 500	PN 25	106390019	7.2	5	5	142.4	711.8	4	860	3	95
MDR DN 500	PN 40	106390028	12.2	5	5	198.7	993.5	4	860	3	95
MDR DN 500	PN 50	106390079	13.2	5	5	210.4	1,052.1	4	860	3	95
MDR DN 600	PN 32	-	8.0	5	5	181.9	909.5	9	1,525	2	143
MDR DN 600	PN 40	-	11.3	5	5	226.6	1,133.0	9	1,525	2	143

^a PFA: allowable operating pressure | PMA = 1.2 x PFA | PEA = 1.2 x PFA + 5 | higher PFA on request | see instructions on the use of clamping rings

^b theoretical mass of 1 m pipe, incl. ZMA, zinc, top coat and socket portion

^c theoretical mass per pipe, incl. ZMA, zinc, top coat and socket portion, an overmold of approx. 10% is to be expected.

^d Tensile forces due to tensile tests by Berliner Wasserbetriebe water company

¹ Minimum dimension

^{2,3} Nominal dimension

^e with HDR = high-pressure lock



Snow-Specific Information

Tiroler Rohre GmbH – a strong partner

The time window for laying new pipes can be very small, especially for snow-making systems, so it's important to have a partner who can deliver reliably and who can offer advice and support.

Tiroler Rohre GmbH is a strong partner in this field for the following reasons:

- + A partner there for you on site whenever you need us
- + High-quality products
- + 30 years of experience in snow pipes
- + The perfect system partner for your project (planning supervision, construction site supervision, carrying out inspections, creating node plans and material lists)
- + Central warehouse in Hall in Tyrol with a stock of approx. 10,000 tons of pipes and approx. 1,000 tons (= approx. 40,000 pcs.) of fittings, ensuring reliable supply during the construction phase
- + Extensive range of fittings
- + Reliable delivery capability, short delivery distances, no intermediate transportation to construction sites required
- + Delivery by crane truck (even for small quantities)
- + Easy to return
- + Can be bent up to 5 degrees, saving on fittings
- + 100%-restrained system
- + Inserts clearly identifiable to avoid confusion
- + Same system for pipes and fittings
- + Easy disassembly

Checklist

For constructors and planners

+ Texts for use in invitations for tender adapted to the relevant standards

+ Defined award criteria

- Production and storage in Austria
- Type testing, testing laboratory & evidence
- Fast delivery and high availability
- More than 20 different types of fittings stocked in Austria
- AutoCAD libraries for pipes and fittings
- Pipe-laying training & supervision on site
- Technical assistance with planning and implementation
- System supplier (pipes and fittings)

+ Special products & solutions

+ Sustainability

- Short transport distances, recycled raw materials and eco-friendly production
- Durability and high safety reserves
- Environmental protection and hygiene

+ Consistently high quality

- Complete documentation and testing at every stage of production

+ Key data for planners

- Hydraulic measurement: Roughness and flow velocity
- Static measurement: Internal and external forces of the pipe; geometric measurement of the trench/dam; bedding, backfill and trench building conditions; composition of the soil and backfill material
- System measurement: System pressure (DP), maximum System pressure (MDP) & system test pressure (STP) taking all relevant flow conditions into account.

PIPE SYSTEMS



Tiroler Rohre GmbH

Innsbrucker Strasse 51

6060 Hall in Tirol

Austria

T +43 5223 503 0

F +43 5223 436 19

E office@trm.at

www.trm.at

April 2019 All information is supplied without liability.

All data subject to changes and errors. Printing and typesetting errors reserved.

All depictions are symbolic images. Color and design may deviate from depicted products.

Publisher: Tiroler Rohre GmbH

Design: LCEWENZAHM.at

Printing: Alpina Druck GmbH